

HP AMP AES67 POE TM

MANUAL

The AeroAudio HP AMP AES67 PoE TM is a superb well designed studio quality class AB headphone amplifier made for Jocks and producers that hides away and just does the job you need it for.

The +20 year field proven design ensures your ears are safe from annoying cracking audio on touching the volume knob. With a double output for both 3.5 and 6.3mm jack's makes the annoying 'where did I put it' adapters obsolete, just simply connecting all types of studio headphones. The rock solid miniature casing hides away under your desk with a special design so your knees are safe from painfully bumping it. A small bright shining LED let's you find the Amp instantly.

Three key features make this amplifiers outstanding for studio use. The first feature is the high slew rate that prevents odd order distortion anomalies.

The second feature is current-on-demand at the output that enables the amplifier to respond quickly and linearly when necessary without risk of output distortion. When large amounts of output power are suddenly needed, the amplifier can respond extremely quickly without raising the noise floor of the system and degrading the signal-to-noise ratio.

The third feature is the gain-independent frequency response that allows the full bandwidth of the amplifier to be used over a wide range of gain settings.



WARINIG!

Without proper adjustment to the type of headphone used the HP-AMP-AES67 can produce over 100dBA @ +6dBu input level and can cause ear damage! Take proper precautions and make proper settings to ensure the maximum legally allowed output level is not exceeded. AeroAudio strongly advises to adjust input level to be set at 85dBA maximum output level on the headphone. AeroAudio can not be held responsible for any type of damage or injuries in short- or long-term caused by improper installation or use.



HP AMP AES67 POE TM

MANUAL

Network setup

By default the HP-AMP-AES67 is shipped with DHCP on. Without a DHCP server in the network, the AMP can be found using the Dante™ controller software. You can use a direct cable connection between the computer and the AMP. Although a switch can be used, it is not needed. The latest version of the Dante™ controller software can be downloaded from the official Audinate website at <https://www.audinate.com>.

Within the controller software you will find the AMP using the “device info” section.

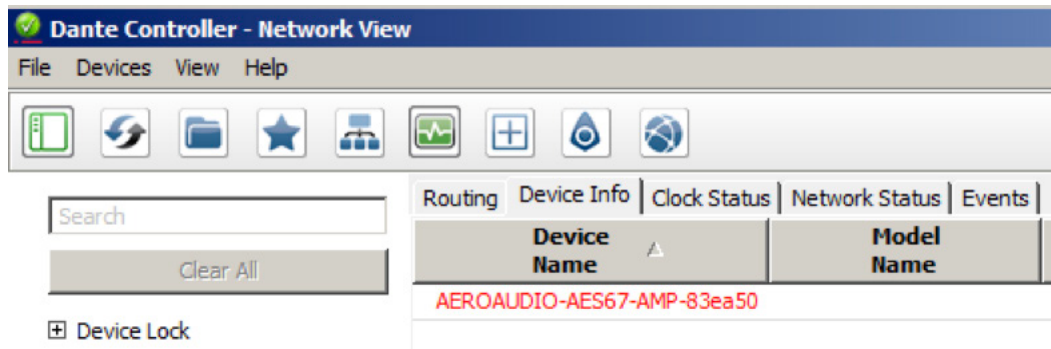

By double clicking the device (in red) you will find the IP range of the AMP.

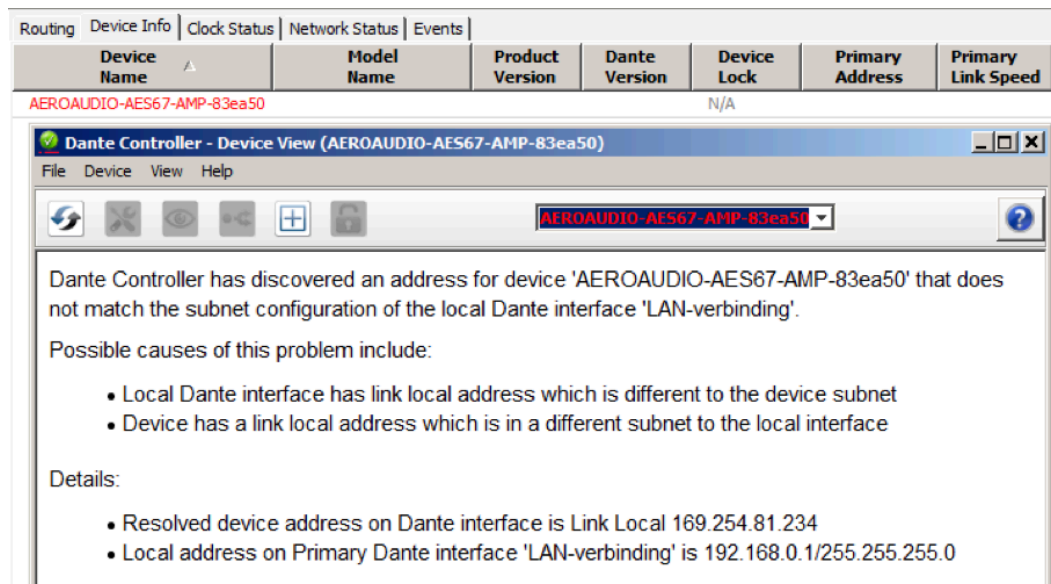

To change setting on the AMP you will need to match the IP address of the computer to the range of the AMP. In this case 169.254.81.xxx



HP AMP AES67 POE TM MANUAL

Now set the computer running the controller software to match within the range of the AMP. In this example we use 169.254.81.101 with subnet 255.255.0.0

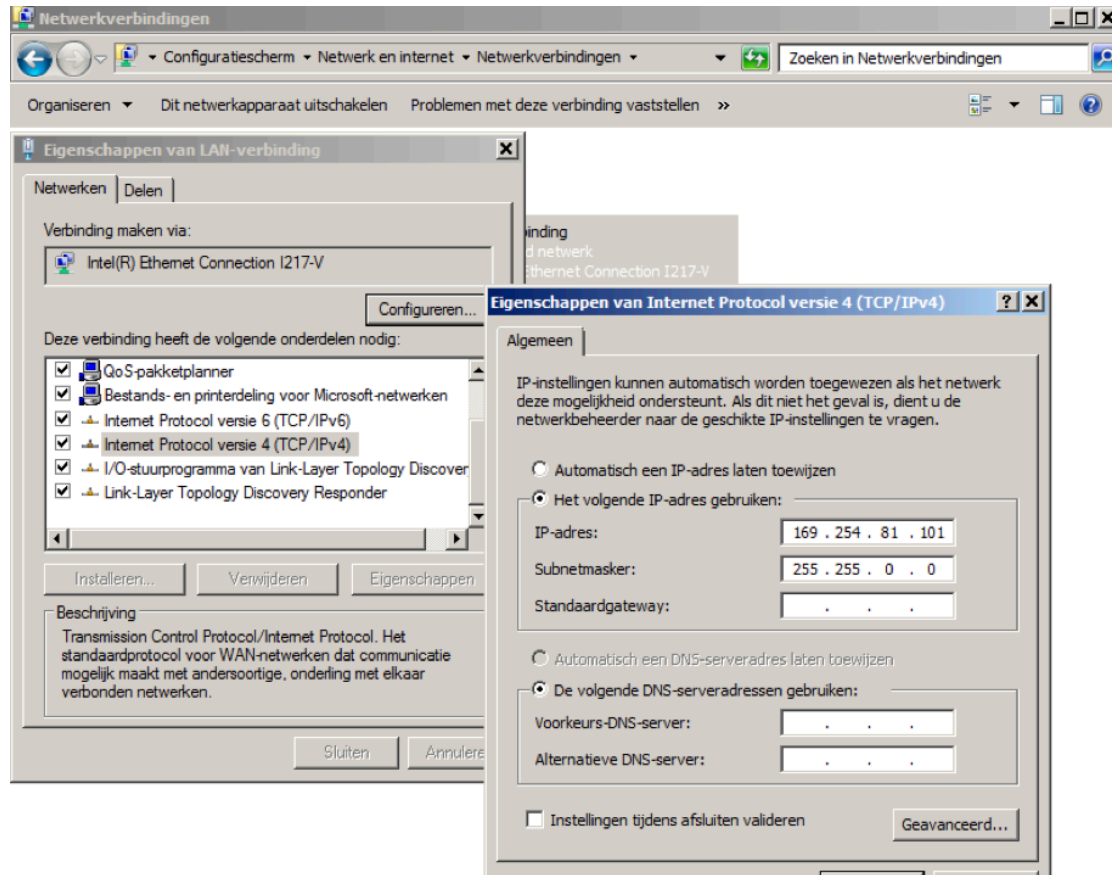

Now the HP-AMP-AES67 will show in black and settings can be changed.

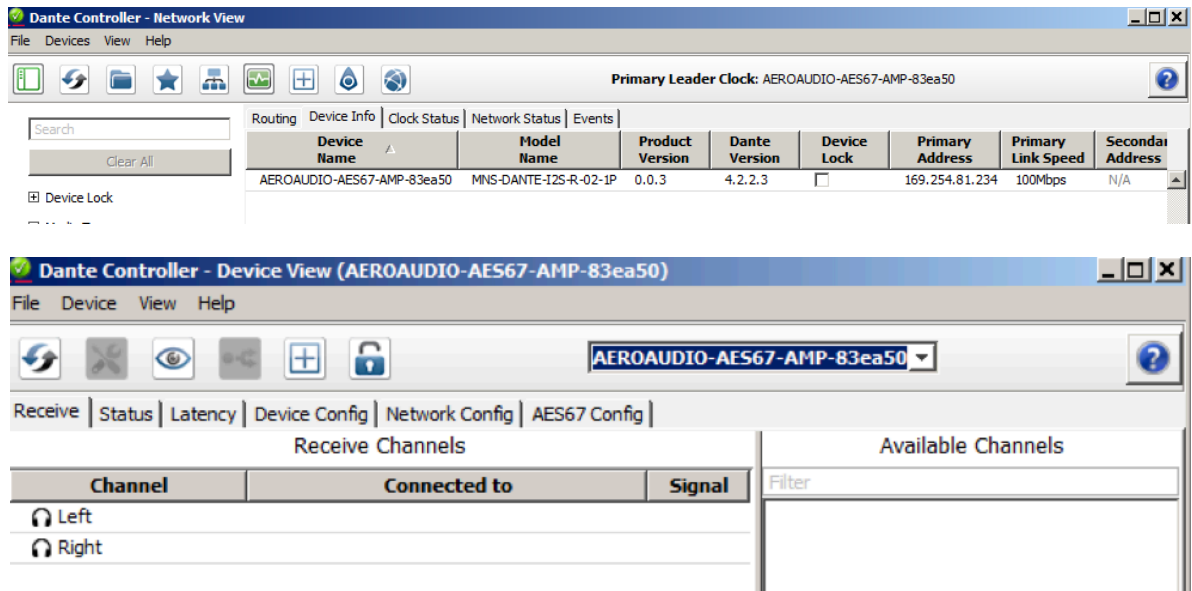



AeroAudio

WWW.AEROAUDIO.EU

HP AMP AES67 POE TM

MANUAL

RAV2SAP
software



By default AES67 is enabled. You can use the Ravenna RAV2SAP control software to enable any AES67 streams to be shown in the Dante™ controller software. The latest version of the RAV2SAP software and manual can be downloaded from the official Ravenna-network website at: www.ravenna-network.com.

Device configuration

The HP-AMP-AES67 supports sample rate conversion. Since by default AES67 is enabled, this option is only available when AES67 has been disabled.

Sample Rate

Sample Rate:	48k	Pull-up/down:	
	44,1k		This device does not support Pull-up/down configuration.
	48k		
	88,2k		
	96k		

By default encoding is set to PCM 24 bit to match optimal encoding of the DA converter.

Encoding	Clocking
Preferred Encoding:	Unicast Delay Requests:
PCM 24	Disabled
PCM 32	
PCM 16	
PCM 24	

Encoding can be changed but can result in loose of audio quality. AeroAudio strongly advices to leave encoding at PCM24 bit.

Where needed Unicast delay requests can be enabled.

Delay is set by default to minimum at 1mS. This can be adjusted upto 5mS, but is not recommended.

Device Latency

Latency:	1,0 msec
	1,0 msec
	2,0 msec
	5,0 msec



AeroAudio

WWW.AEROAUDIO.EU

STEENWEG 148C - 9810 NAZARETH - BELGIUM - T +32 (0)9 396 76 40 - INFO@AEROAUDIO.EU



AeroAudio

WWW.AEROAUDIO.EU

HP AMP AES67 POE TM

MANUAL

Since the HP-AMP-AES67 is connected by a single network cable, redundancy is not supported. Network settings can be changed to match the used AES67 or Dante™ network.

Dante Redundancy

Current:

New:

This feature cannot be configured

Addresses

Obtain an IP Address Automatically (default)

Manually configure an IP Address

IP Address: . . .

Netmask: . . .

DNS Server: . . .

Gateway: . . .

Reset Device



AeroAudio

WWW.AEROAUDIO.EU

STEENWEG 148C - 9810 NAZARETH - BELGIUM - T +32 (0)9 396 76 40 - INFO@AEROAUDIO.EU



AeroAudio

WWW.AEROAUDIO.EU

HP AMP AES67 POE TM MANUAL

Connections: 6.35mm and 3.5mm stereo jack

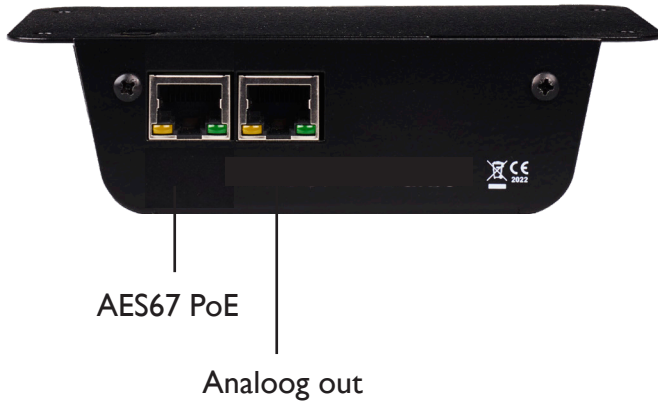
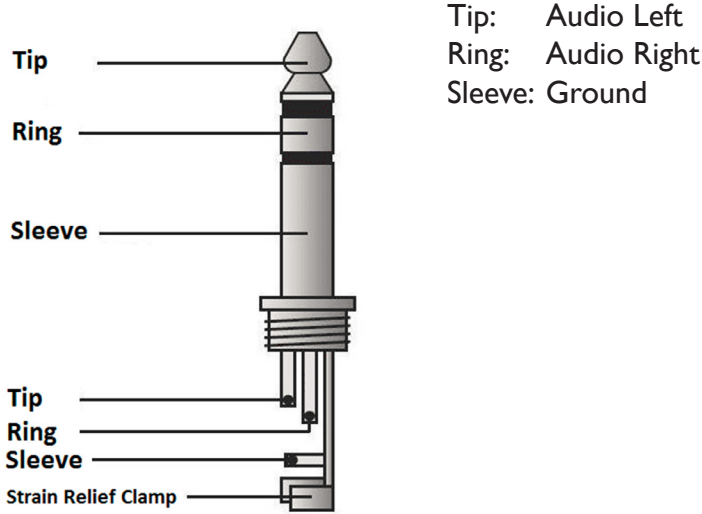

Analog balanced output

for Adding extra analog headphone amps from AeroAudio. (HPAMP FM/TM and/or HPAMP DSP FM/TM.)

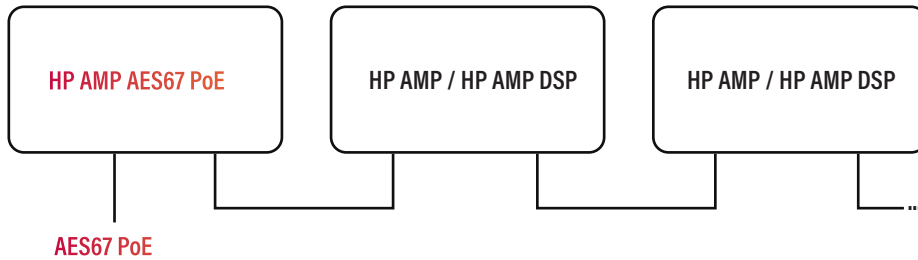

AeroAudio

WWW.AEROAUDIO.EU

STEENWEG 148C - 9810 NAZARETH - BELGIUM - T +32 (0)9 396 76 40 - INFO@AEROAUDIO.EU



AeroAudio

WWW.AEROAUDIO.EU

HP AMP AES67 POE TM

MANUAL

TECHNICAL SPECIFICATIONS

Maximum output power per channel @1Khz: 300mW at 32 ohm

Distortion @ 1Khz, 100mW: < 98dB

Channel separation @1Khz: < 101dB

Frequency response: 22Hz – 22KHz

Gain: -100 ~ 0dB

Encoding: PCM16, PCM24, PCM32

Sample rates: 44.1 KHz, 48KHz, 88.2KHz, 96KHz

Audio standard: AES67 and Dante™ enabled.



AeroAudio

WWW.AEROAUDIO.EU

STEENWEG 148C - 9810 NAZARETH - BELGIUM - T +32 (0)9 396 76 40 - INFO@AEROAUDIO.EU



AeroAudio

WWW.AEROAUDIO.EU

HP AMP AES67 POE TM

MANUAL

DIMENSIONS

135 mm * 76,3mm * 36mm

Weight: 0.3 Kg

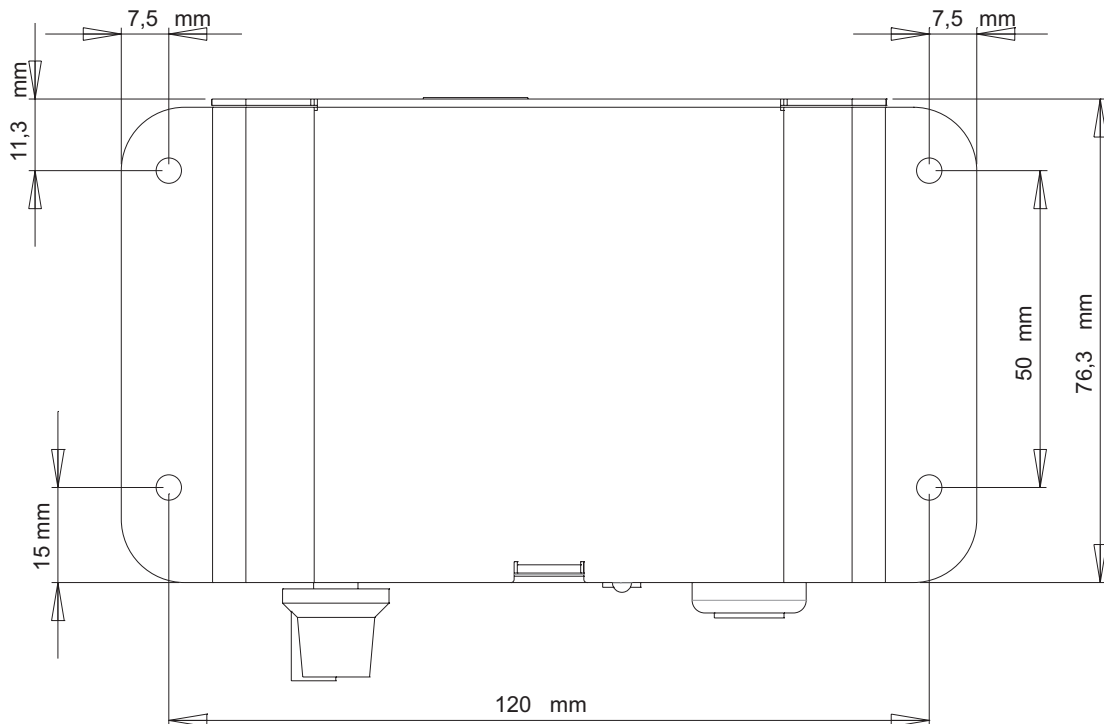
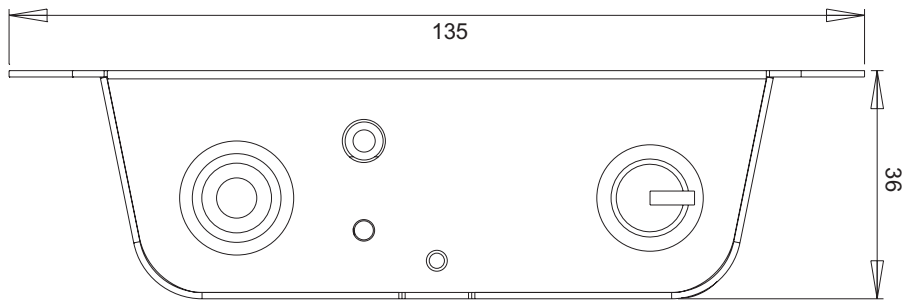

AeroAudio

WWW.AEROAUDIO.EU

STEENWEG 148C - 9810 NAZARETH - BELGIUM - T +32 (0)9 396 76 40 - INFO@AEROAUDIO.EU



AeroAudio

WWW.AEROAUDIO.EU

HP AMP AES67 POE TM

MANUAL

Safety First!

- Caution: hot and sharp surfaces! This professional device may only be installed by qualified personnel.
- Check the cardboard box for any damage upon receipt of the goods. In case of a damaged box, please contact your distributor before opening it. contact your distributor before opening the box.
- Read all documentation before using the unit.
- Keep all documentation for future reference.
- Keep the box and the packaging material even if the equipment has arrived in good condition.
- Should you ever need to ship the appliance, use only the original factory packaging.
- Do not spill water or other liquids in or on the device.
- Always use the power supply provided.
- Make sure that the power outlets correspond to the power requirements indicated on the back of the power supply.
- Do not use the device if the power cord is frayed or broken.
- Turn off and disconnect the devices from the mains before making any connections.
- Do not use the device near heaters, heating grills, radiators or other heat producing devices.
- Do not use the unit on a surface or in an environment that may interfere with the normal flow of air around the unit.
If the unit is used in an extremely dusty or smoky environment, the unit should be "dusted" regularly.
- Do not remove the cover. Removing the cover will expose you to potentially dangerous voltages.
- In case of malfunction, this unit should only be serviced by qualified service personnel.
- Always follow the instructions of the supplier and manufacturer - Only use accessories, spare and replacement parts specified by the manufacturer.
- Only use the device for the purpose intended by the manufacturer.



AeroAudio

WWW.AEROAUDIO.EU

STEENWEG 148C - 9810 NAZARETH - BELGIUM - T +32 (0)9 396 76 40 - INFO@AEROAUDIO.EU